

F-1-A LUBRICATOR and ACCESSORIES FOR STEAM DRIVEN AIR COMPRESSORS

Parts Catalog No. 3204-5 Sup. 8

May 1940
Reprinted October 1955

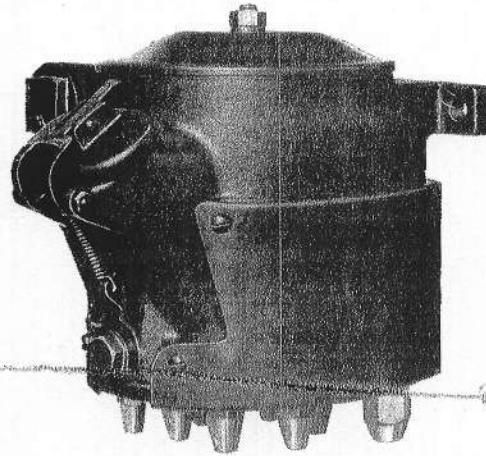

Westinghouse Air Brake COMPANY

AIR BRAKE DIVISION  WILMERDING, PA.

F-1-A LUBRICATOR

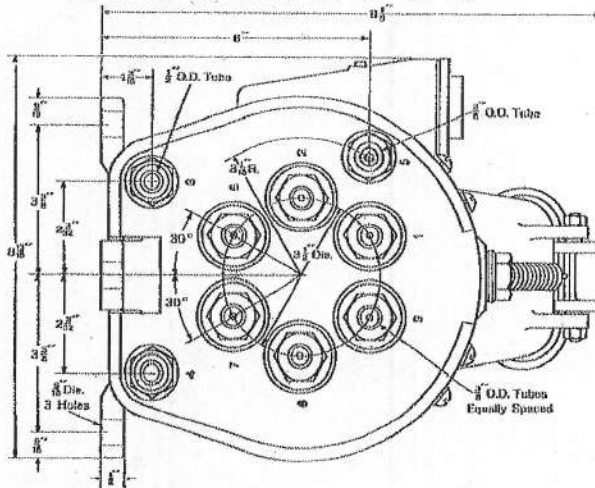
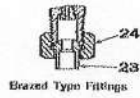
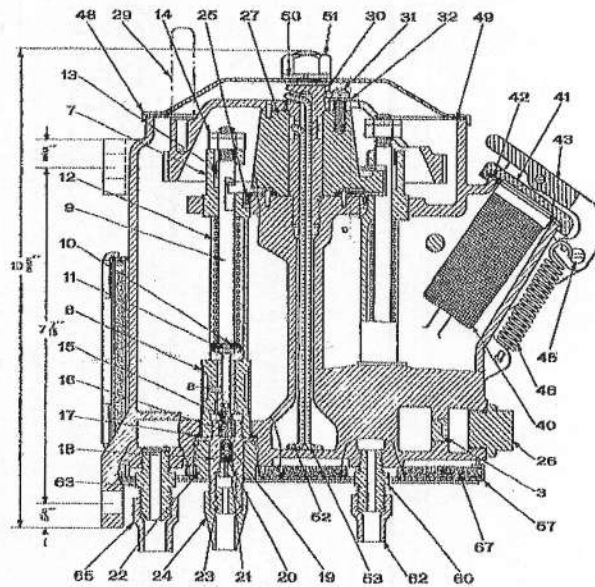
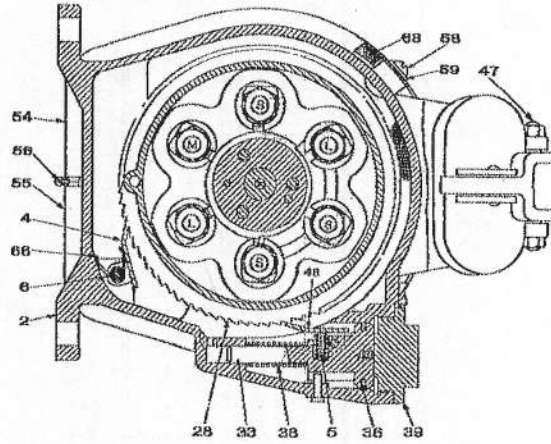

Net Weight 46 lbs. 6 Feed
Net Weight 43½ lbs. 5 Feed

F-1-A LUBRICATOR

Piece No. 512879 F-1-A Lubricator (6 Feed), with Flared Type Fittings, complete
 Piece No. 512880 F-1-A Lubricator (5 Feed), with Flared Type Fittings, complete
 Piece No. 513449 F-1-A Lubricator (6 Feed), with Brazed Type Fittings, complete
 Piece No. 513454 F-1-A Lubricator (5 Feed), with Brazed Type Fittings, complete

Pc. No.	Ref. No.	Description	Pc. No.	Ref. No.	Description
504024	2	Body, complete (includes 3, 4, 6 and 66)	74276	36	Piston Ring
515790	3	Special Pipe Plug	504061	38	Piston Spring
504028	4	Ratchet (2 Req'd)	504062	39	Piston Cap Nut
504029	5	Ratchet Spring	504063	40	Filler Strainer, complete (2 Req'd)
504041	6	Ratchet Pin	504067		Oil Filler Cover, complete (includes 41, 42 and 43)
512881		Pump Body, complete (Large) (2 Req'd)	504068	41	Oil Filler Cover
504030		Pump Body, complete (Medium)	504069	42	Oil Filler Cover Gasket
512882		Pump Body, complete (Small)	504070	43	Oil Filler Cover Handle
512839	7	Pump Body (Large) (includes 8)	504072	45	Hinge Screw (2 Req'd)
507404	7	Pump Body (Medium) (includes 8)	504073	46	Cover Spring
512858	7	Pump Body (Small) (includes 8)	500589	47	1/4" Hex. Nut (2 Req'd)
*514201	8	Strainer	504074	48	Cover, complete (includes 49)
512836	9	Plunger with Key (Large) (includes 13) (3 Req'd)	504076	49	Cover Gasket
507428	9	Plunger with Key (Medium) (includes 13)	15951	50	1/2" Lock Washer
512856	9	Plunger with Key (Small) (includes 13)	10829	51	1/2" Hex. Nut, WING
*504037	10	Spring Washer	515792	52	Wick (1/8"x9 1/8")
*504038	11	Spring Seat Retainer	515793	53	Wick (1/8"x10 5/8")
512837	12	Plunger Spring (Large) (2 Req'd)	504400		Insulation Cover, complete (includes 54, 55 and 56)
504039	12	Plunger Spring (Medium)	504389	54	Left Hinge Portion
513413	12	Plunger Spring (Small)	504390	55	Right Hinge Portion
*96458	13	Key	504399	56	Pin
*515791	14	Lock Nut	504391	57	Insulation Base
*503634	15	Ball Check	6271	58	1/4"x1 1/8" Ov. Hd. Mch. Screw (4 Req'd)
*504042	16	Ball Check Spring	10764	59	1/4" Lock Washer (4 Req'd)
*504043	17	Pump Body Gasket	506367		Flared Type Stud, complete for 3/8" O.D. Copper Tube (Air Engine Connection) (includes 60 and 62)
*504044	18	Stud	513978		Brazed Type Stud, complete for 3/8" O.D. Copper Tube (Air Engine Connection) (For details, see page 4)
*504045	19	Ball Check	506157	60	Flared Type Stud
*504046	20	Ball Check Spring	504089	61	Blanking Disc
*504047	21	Spring Retainer	506445	62	Flared Type Tubing Nut
*504048	22	Pump Clamping Nut	506385		Flared Type Stud, complete for 1/2" O.D. Copper Tube (Heater Pipe Connection) (includes 63 and 65)
*504396	23	Special Flared Type Sleeve	28305		Brazed Type Stud, complete, for 1/2" O.D. Copper Tube (Heater Pipe Connection) (2 Req'd) (For details see page 4)
*514956	23	Brazed Type Swivel	506442	63	Flared Type Stud (2 Req'd)
*504395	24	Flared Type Union Nut	506446	65	Flared Type Tubing Nut (2 Req'd)
*504050	24	Brazed Type Nut	510067	66	Ratchet Spring
504051	25	Pump Body Retainer	514230	67	Base Insulation
504052	26	Cap Nut	514229	68	Side Insulation (2 Req'd)
504053	27	Cam			
504055	28	Ratchet Wheel			
504056	29	Handle			
504057	30	Cam Retainer			
1362	31	1/4"x5 5/8" Ov. Hd. Mch. Screw (3 Req'd)			
10764	32	1/4" Lock Washer (3 Req'd)			
512892	33	Piston, complete, less Ring (includes 4 and 5)			

†NOTE A—3 Required for 6 Feed Lubricator and 2 Required for 5 Feed Lubricator.
 *NOTE B—6 Required for 6 Feed Lubricator and 5 Required for 5 Feed Lubricator.

SPRING IDENTIFICATION

The following table is shown to enable railroad men, storekeepers and all Air Brake men to identify the various springs used in the F-1-A Lubricator and Accessories cataloged herein. It is based on calculated figures and the actual spring will vary somewhat, due to small difference in wire diameter, coil diameter, number of turns, etc. This tabulation is intended for identification only and should not be used for any other purpose. It does not represent a specification for the spring mentioned.



Pc. No.	Approx. Out. Dia. "A"	Approx. Dia. Wire "B"	Approx. Free Height "C"	** Approx. No. Turns	Material	Name of Spring	Where Used
504029	3/8"	.032"	3 1/2"	10 1/2	Bronze	Ratchet Spring	F-1-A Lubricator
512837	3/8"	.060"	4.482"	23	Steel	Plunger Spring	F-1-A Lubricator
504039	3/8"	.081"	4.05"	23	Steel	Plunger Spring	F-1-A Lubricator
513413	3/8"	.073"	3.88"	27	Steel	Plunger Spring	F-1-A Lubricator
504042	3/8"	.0181"	3 1/4"	10	Steel	Ball Check Spring	F-1-A Lubricator
504046	3/8"	.0169"	668"	12 1/2	Bronze	Ball Check Spring	F-1-A Lubricator
504061	1/8"	.063"	2 1/4"	14	Steel	Piston Spring	F-1-A Lubricator
504073	1/8"	.099"	1 3/4"	19	Steel	Cover Spring	F-1-A Lubricator
513436	2 1/2"	.054"	1.1434"	14	Steel	Check Valve Spring	Union Fitting

**NOTE—Number of turns for spring counted between extreme ends of the wire.

Prices will be quoted upon application
 Orders should give PIECE NUMBER and NAME of part wanted

TERMINAL FITTINGS FOR F-1-A LUBRICATOR

STRAIGHT TYPE UNION STUD FITTING
WITH WING CHECK VALVE

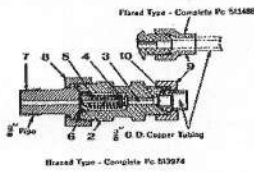

Net Weight 3/4 lb.

Piece No. 513488 Flared Type Union Stud Fitting with Wing Check Valve, complete

Piece No. 513974 Brazed Type Union Stud Fitting with Wing Check Valve, complete

Pc. No.	Ref. No.	Description
513504	2	Check Valve Body, complete (includes 3, 4, 5 and 6) for Pc. 513488
513975	2	Check Valve Body, complete (includes 3, 4, 5 and 6) for Pc. 513974
512041	3	Valve
512043	4	Spring Seat
513436	5	Check Valve Spring
513437	6	Spring Retainer
506268	7	Stud
506269	8	Union Nut
506445	9	Flared Type Tubing Nut
504050	9	Brazed Type Coupling Nut
21465	10	Brazed Type Union Swivel

ELBOW TYPE UNION FITTING
WITH WING CHECK VALVE

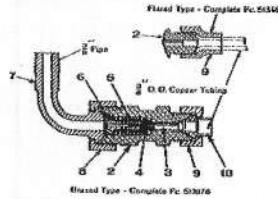

Net Weight 13 ozs.

Piece No. 513489 Flared Type Union Elbow Fitting with Wing Check Valve, complete

Piece No. 513976 Brazed Type Union Elbow Fitting with Wing Check Valve, complete

Pc. No.	Ref. No.	Description
513504	2	Check Valve Body, complete (includes 3, 4, 5 and 6) for Pc. 513489
513975	2	Check Valve Body, complete (includes 3, 4, 5 and 6) for Pc. 513976
512041	3	Valve
512043	4	Spring Seat
513436	5	Check Valve Spring
513437	6	Spring Retainer
506441	7	Elbow
506269	8	Union Nut
506445	9	Flared Type Tubing Nut
504050	9	Brazed Type Coupling Nut
21465	10	Brazed Type Union Swivel

STUD FOR AIR CONNECTION IN
COMPRESSOR CENTER PIECE

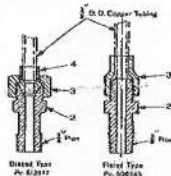

Net Weight 1/4 lb.

Piece No. 513977 Brazed Type Stud, complete

Piece No. 506345 Flared Type Stud, complete

Pc. No.	Ref. No.	Description
513458	2	Stud (Brazed Type)
506444	2	Stud (Flared Type)
504050	3	Nut (Brazed Type)
506445	3	Nut (Flared Type)
21465	4	Swivel (Brazed Type)

STEAM CHOKE FOR HEATER
PIPE CONNECTION

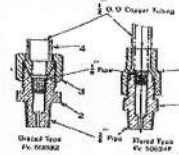

Net Weight 1/4 lb.

Piece No. 513980 Brazed Type Stud, complete

Piece No. 506347 Flared Type Stud, complete

Pc. No.	Ref. No.	Description
513457	2	Stud (Brazed Type)
506443	2	Stud (Flared Type)
28302	3	Nut (Brazed Type)
506446	3	Nut (Flared Type)
28303	4	Swivel (Brazed Type)

STUD FOR HEATER PIPE CONNECTION
AT LUBRICATOR

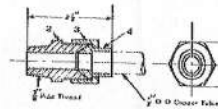

Net Weight 5 ozs.

Piece No. 28305 Brazed Type Stud, complete

Pc. No.	Ref. No.	Description
28304	2	Stud
28302	3	Nut
28303	4	Swivel

STUD FOR AIR CONNECTION AT LUBRICATOR

Piece No. 513978 Brazed Type Stud, complete

Piece No. 506367 Flared Type Stud, complete

Pc. No.	Ref. No.	Description
513446	2	Stud (Brazed Type)
506157	2	Stud (Flared Type)
504050	3	Nut (Brazed Type)
506445	3	Nut (Flared Type)
21465	4	Swivel (Brazed Type)

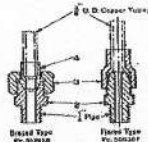

Net Weight 3 ozs.

Piece No. 506385 Flared Type Stud, complete

Pc. No.	Ref. No.	Description
506442	2	Stud
506446	3	Nut

Net Weight 5 ozs.

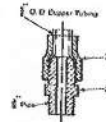

NOTE—For Spring Identifications Table, See Page 3

Prices will be quoted upon application

Orders should give PIECE NUMBER and NAME of part wanted

WESTINGHOUSE AIR BRAKE COMPANY

PITTSBURGH, PA.

F-1 LUBRICATOR AND ACCESSORIES

FOR STEAM DRIVEN AIR COMPRESSOR

PART CATALOG NO. 3204-5

SUPPLEMENT NO. 7

APRIL, 1937

(SUPERSEDING ISSUE OF OCTOBER, 1936)

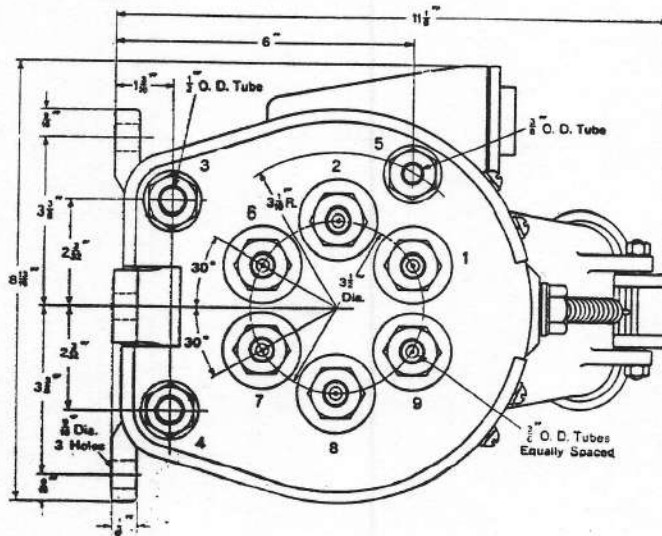
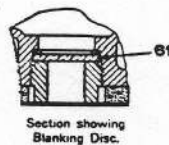
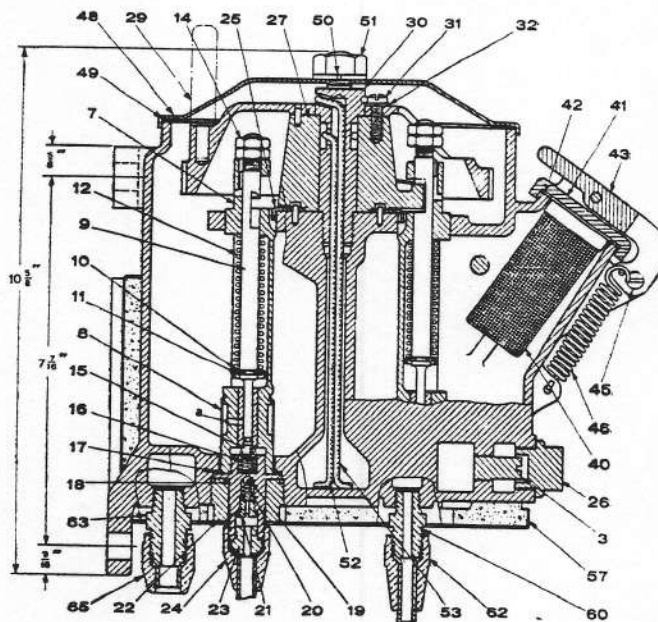
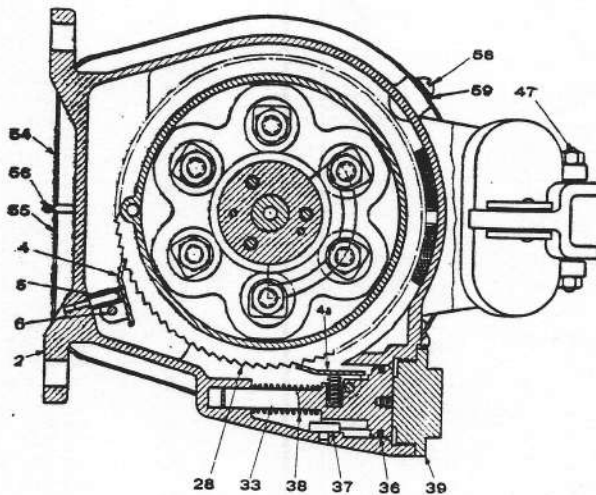

WESTINGHOUSE AIR BRAKE COMPANY

F-1 LUBRICATOR AND ACCESSORIES
FOR STEAM DRIVEN AIR COMPRESSOR

Pc.No.	Ref.No.	
504023		F-1 Lubricator, complete
504316		F-1 Lubricator, complete, Connection to Air Side of Governor Blanked
504025	2	Body, complete
504027	3	Special Plug
504028	4	Ratchet
504029	5	Ratchet Spring
504041	6	Ratchet Pin
504030		Pump, complete (6 Req'd. for Pc.504023 and 5 Req'd. for Pc.504316)
507404	7	Pump Body, Bushed (Includes 8) (6 Req'd. for Pc.504023 and 5 Req'd. for Pc.504316)
504034	8	Strainer (6 Req'd. for Pc.504023 and 5 Req'd. for Pc.504316)
507428	9	Plunger (6 Req'd. for Pc.504023 and 5 Req'd. for Pc.504316)
504037	10	Spring Washer (6 Req'd. for Pc.504023 and 5 Req'd. for Pc.504316)
504038	11	Spring Seat Retainer (6 Req'd. for Pc.504023 and 5 Req'd. for Pc.504316)
504039	12	Plunger Spring (6 Req'd. for Pc.504023 and 5 Req'd. for Pc.504316)
507429	14	Jam Nut (12 Req'd. for Pc.504023 and 10 Req'd. for Pc.504316)
503634	15	5/16" Ball Check (6 Req'd. for Pc.504023 and 5 Req'd. for Pc.504316)
504042	16	Ball Check Spring (6 Req'd. for Pc.504023 and 5 Req'd. for Pc.504316)
504043	17	Pump Body Gasket (6 Req'd.)
504044	18	Stud (6 Req'd. for Pc.504023 and 5 Req'd. for Pc.504316)
504045	19	3/16" Ball Check (6 Req'd. for Pc.504023 and 5 Req'd. for Pc.504316)
504046	20	3/16" Ball Check Spring (6 Req'd. for Pc.504023 and 5 Req'd. for Pc.504316)
504047	21	Spring Retainer (6 Req'd. for Pc.504023 and 5 Req'd. for Pc.504316)
504048	22	Pump Clamping Nut (6 Req'd. for Pc.504023 and 5 Req'd. for Pc.504316)
504396	23	Special Sleeve (6 Req'd. for Pc.504023 and 5 Req'd. for Pc.504316)
504395	24	Union Nut (6 Req'd. for Pc.504023 and 5 Req'd. for Pc.504316)

Pc.No.	Ref.No.	
504051	25	Pump Body Retainer
504052	26	Cap Nut
504053	27	Cam, complete
504055	28	Ratchet Wheel
504056	29	Handle
504057	30	Cam Retainer
1562	31	1/4" x 5/8" Ov.Fil.Hd.Mch.Screw (3 Req'd.)
10764	32	1/4" Lock Washer (3 Req'd.)
504058	33	Piston, complete, less Ring (Includes 4 and 5)
74276	36	Piston Ring
504060	37	Guide Pin
504061	38	Piston Spring
504062	39	Piston Cap Nut
504063	40	Filler Strainer, complete (2 Req'd.)
504067		Oil Filler Cover, complete (Includes 41,42 and 43)
504068	41	Oil Filler Cover
504069	42	Oil Filler Cover Gasket
504070	43	Oil Filler Cover Handle
504072	45	Hinge Screw (2 Req'd.)
504073	46	Cover Spring
500589	47	1/4"-20 Hex.Nuts (2 Req'd.)
504074	48	Cover, complete (Includes 49)
504076	49	Cover Gasket
15951	50	1/2" Lock Washer
10829	51	1/2" Hex.Nut
	52	1/8" x 9-1/8" Wick
	53	1/8" x 10-5/8" Wick
504400		Insulation Cover, complete (Includes 54,55 and 56)
504389	54	Left Hinge Portion
504390	55	Right Hinge Portion
504399	56	.092" x 4-3/4" Pin
504391	57	Insulation Base
6271	58	1/4"-20 x 5/16" Ov.Hd.Mch.Screw (4 Req'd.)
10764	59	1/4" Lock Washer
506157	60	Stud
504089	61	Blanking Disc for Pc.504316
506445	62	Tubing Nut (For 3/8" O.D. Tube)
506442	63	Stud (2 Req'd.)
506446	65	Tubing Nut (For 1/2" O.D. Tube) (2 Req'd.)

Prices will be quoted upon application.
Orders should give PIECE NUMBER and NAME of part wanted.

1-C-2
Printed in U.S.A.

1a

ACCESSORIES FOR F-1 LUBRICATOR

UNION TYPE ELBOW WITH BALL CHECK FOR
OIL DELIVERY LINES

Piece No. 506386 Union Type Elbow with
Ball Check, complete
(4 Req'd.)

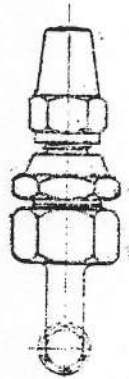
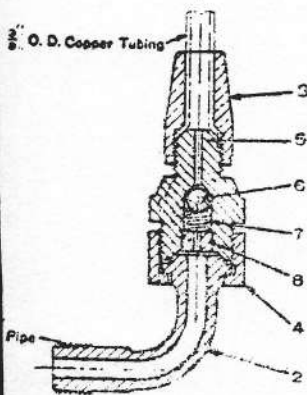

Pc.No. Ref.No.

506441	2	Elbow (4 Req'd.)
506445	3	Tubing Nut for 3/8" O. D.Tube (4 Req'd.)
506269	4	Union Nut (4 Req'd.)
506440	5	Body (4 Req'd.)
503634	6	5/16" Ball (4 Req'd.)
506507	7	Ball Check Spring (4 Req'd.)
506439	8	Spring Retainer (4 Req'd.)

UNION TYPE STUD WITH BALL CHECK FOR
OIL DELIVERY LINES

Piece No. 506371 Union Type Stud with
Ball Check, complete
(2 Req'd.)

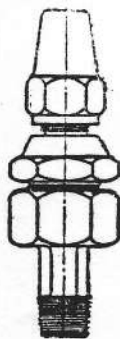
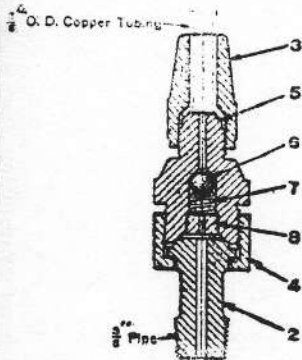

Pc.No. Ref.No.

506268	2	Stud (2 Req'd.)
506445	3	Tubing Nut for 3/8" O. D.Tube (2 Req'd.)
506269	4	Union Nut (2 Req'd.)
506440	5	Body (2 Req'd.)
503634	6	5/16" Ball (2 Req'd.)
506507	7	Ball Check Spring (2 Req'd.)
506439	8	Spring Retainer (2 Req'd.)

Prices will be quoted upon application.

Orders should give PIECE NUMBER and NAME of part wanted.

ACCESSORIES FOR F-1 LUBRICATOR (CONT'D.)

STUD FOR AIR ENGINE CONNECTION IN COMPRESSOR
CENTER PIECE

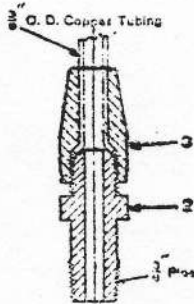

Piece No. 506345 Stud, complete

Pc.No.	Ref.No.	
506444	2	Stud
506445	3	Tubing Nut for 3/8" O. D. Tube

STEAM CHOKE FOR HEATER PIPE

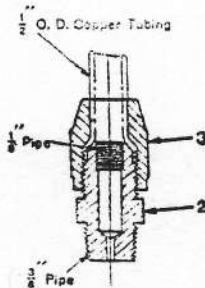

Piece No. 506347 Steam Choke, complete

Pc.No.	Ref.No.	
506443	2	Stud
506446	3	Tubing Nut for 1/2" O.D. Tube

STUD FOR HEATER PIPE CONNECTION AT LUBRICATOR

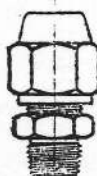
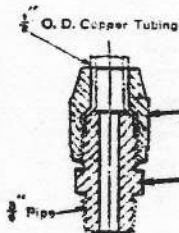

Piece No. 506385 Stud, complete

Pc.No.	Ref.No.	
506442	2	Stud
506446	3	Tubing Nut for 1/2" O.D. Tube

Piece No. 506109 Clamp, complete, for 1/2" O.D. Copper Tube
 Piece No. 506112 Clamp, complete, for 3/8" O.D. Copper Tube

Prices will be quoted upon application.
 Orders should give PIECE NUMBER and NAME of part wanted.